

THIS DRAWING IS UNPUBLISHED. RELEASED FOR PUBLICATION  
 © COPYRIGHT BY TYCO ELECTRONICS CORPORATION. ALL RIGHTS RESERVED.

LOC	DIST	REVISIONS			
P	LTR	DESCRIPTION	DATE	DWN	APVD
G	86	P	REDRAWN PER 0G3A-0395-04	02JUN04	JR MS

- 1 TONGUE MATERIAL THICKNESS .048±.003
- △ 2 BODY: COPPER PER ASTM B-152  
TIN PER ASTM B-545  
INSULATION: PVC, COLOR - YELLOW  
METALLIC SLEEVE: COPPER PER ASTM B-152  
METALLIC BAND: STEEL PER ASTM A109
- 3 FOR .436 MAX WIRE INSULATION DIA

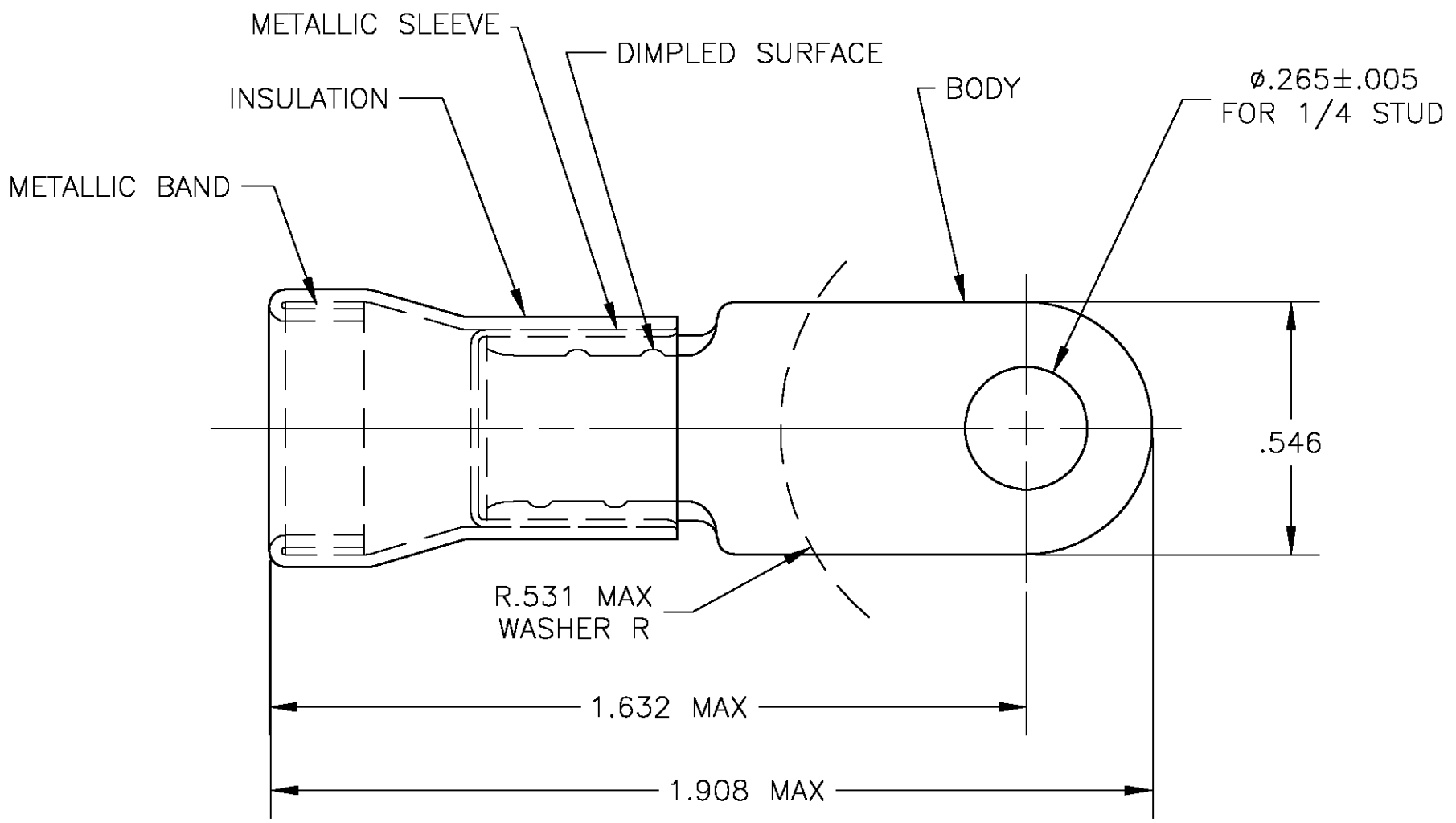

QTY	DESCRIPTION	PART NO
1	WIRE TERMINAL	322053

THIS DRAWING IS A CONTROLLED DOCUMENT.		DWN jr_ruth 02JUN04	Tyco Electronics Corporation Harrisburg, PA 17105	
DIMENSIONS: INCHES		CHK MJ SPICER 02JUN04		
		APVD MJ SPICER 02JUN04	NAME TERMINAL, AMPLI-BOND, RING TONGUE WIRE SIZE: 4	
TOLERANCES UNLESS OTHERWISE SPECIFIED:		PRODUCT SPEC	RESTRICTED TO	
0 PLC ± - 1 PLC ± - 2 PLC ± - 3 PLC ± .008 4 PLC ± - ANGLES ± 5°		APPLICATION SPEC	SIZE A3	CAGE CODE 00779
MATERIAL - △ 2		FINISH - △ 2	DRAWING NO C-322053	SCALE 3:1
CUSTOMER DRAWING			SHEET 1 OF 1	REV P